

Week 4 Monday 25th January:

Literacy: The three little pigs

This week we are going to concentrate on how to use words with suffixes. Today you are going to listen to the story of 'The three little pigs'. You are then going to look through the story to spot all of the suffixes. You are going to write each suffix word and sort it into a suffix table. Please look at the example table given. Please find a copy of the story as a PDF on tapestry as well as on the school website.

As an extra challenge, can you spot any conjunctions or adjectives used in the story?



Maths: 2D faces on 3D shapes

Now that we have explored the properties of 2D and 3D shapes over the last two weeks, we are going to find 2D faces on 3D shapes. Take a look at Today's video lesson on Tapestry and follow the three activities. On page 4 of this document there are also examples of 3D shape nets to explore the 2D faces on the 3D shapes.

Theme: Oceans of the world

This week our theme learning is all about the wonderful oceans within our world. For today's theme, we would like you to watch Miss John's video explaining the five oceans (through a PowerPoint) and a video from BBC Bitesize Oceans (please see link on the next page). Once you have watched both, we'd like you to create a picture of the world with the labelled oceans (please see page 7 for ideas).

Phonics: ue

Read the following words and verbally put one or two into a sentence: clue, blue, issue, argue.

Next segment and spell the following words; true, glue, Sue. Put the sound buttons under each word.

Now sort real and alien words with the ue sound using the video on tapestry. Practise reading the tricky words little, what, oh, their.

Spelling word of the day:

steak

Please watch the video for today's spelling activity.

Handwriting:

Please watch the video for today's handwriting practice.

Practice writing the letters 'ed' in cursive.

Complete two lines of the letters 'ed' and then try using it in the word 'bed'.

Then see if you can think of your own words with these letters in.

Additional resources and videos for today:

Literacy:

BBC bitesize, what are suffixes?: <https://www.bbc.co.uk/bitesize/topics/z8mxrwx/articles/zmgbcwx>

Maths:

Miss John's Maths lesson video: [Tapestry](#)

Faces of 3D shapes video: <https://www.youtube.com/watch?v=O4eNWSxslH4>

3D shapes I know video song: <https://www.youtube.com/watch?v=2cg-Uc556-Q>

Theme:

Miss John's video using PowerPoint: [Tapestry](#)

BBC Bitesize Oceans: <https://www.bbc.co.uk/bitesize/topics/z849q6f/articles/zmqwscw>

5 Oceans Song: <https://www.youtube.com/watch?v=X6BE4VcYngQ>

Literacy

Suffix table

<i>-ed</i>	<i>-ing</i>	<i>-est</i>	<i>-ly</i>	<i>-er</i>

Maths

3D Shape Nets

This is an extra activity (linked to activity 2) if you wish to complete it to extend your learning in exploring 2D faces on 3D shapes. You could print out the nets, cut them and glue them together to create the shapes.

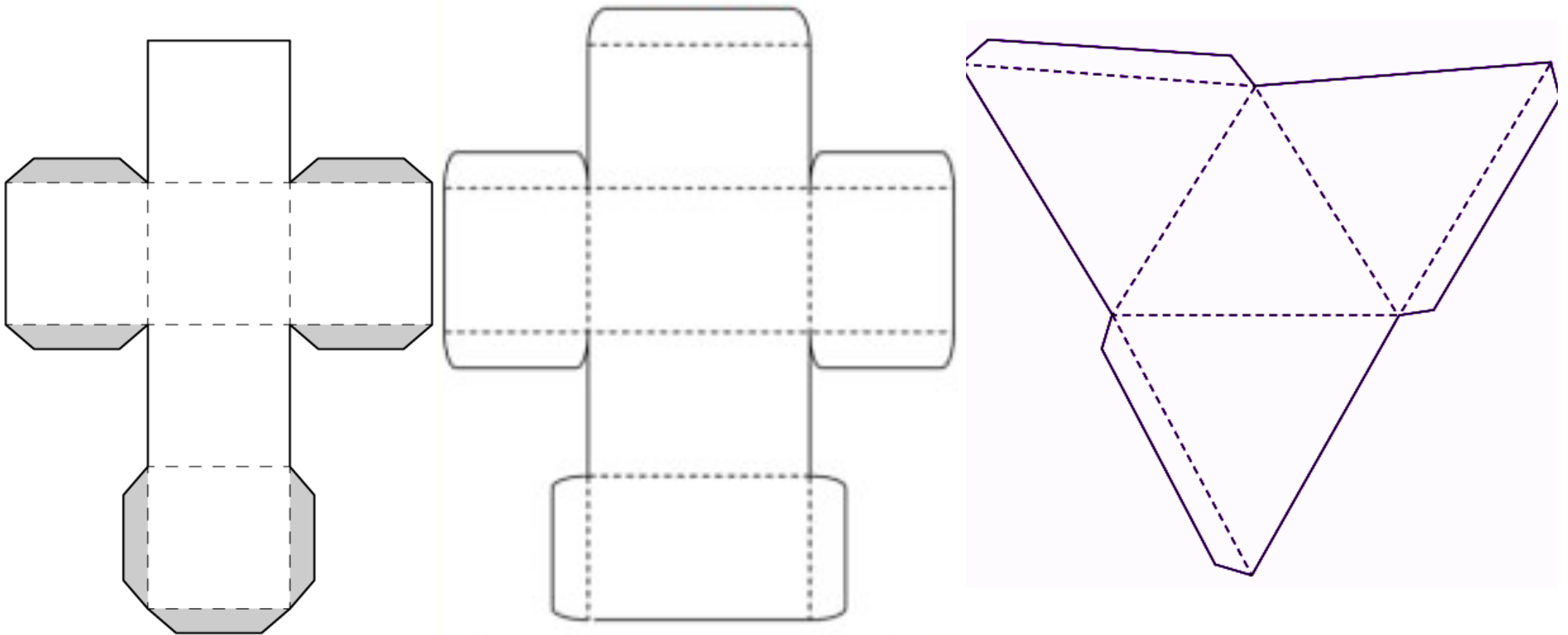

Phonics

ue - Real or alien word?

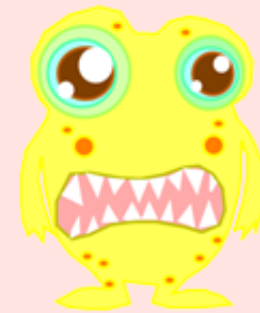

clue

slue

chescue

Sue

penue

value

zued

argue

Phonics

Support for parents/carers

Please find below explanations of some of the words that your children may use during their phonics learning. We hope this will be useful for you, please don't hesitate to message us if you need any further support.

Segmenting:

Segmenting is breaking down a word into the phonemes (sounds) that make up the word. It is an important skill when learning to read and spell words.

Blending:

Blending is a vital skill in learning to read. Blending is when children say the sounds that make up a word and then merge these sounds together to hear the word.

Phoneme:

A phoneme is the smallest unit of sound and phonemes can be put together to make words. For example, when sounding out a word, each sound within the word is called a phoneme.

Grapheme:

Grapheme means the way a sound is written. For example, this week children are learning the oo sound but looking at all the different ways of spelling this sound. Those ways of spelling are called the graphemes. The graphemes for the oo sound are ew, ue, u-e, ou, oo.

Ideas for today's theme activity:

